

Sue Pemberton

Cambridge IGCSE[®] and O Level

Additional Mathematics

Coursebook

Second edition

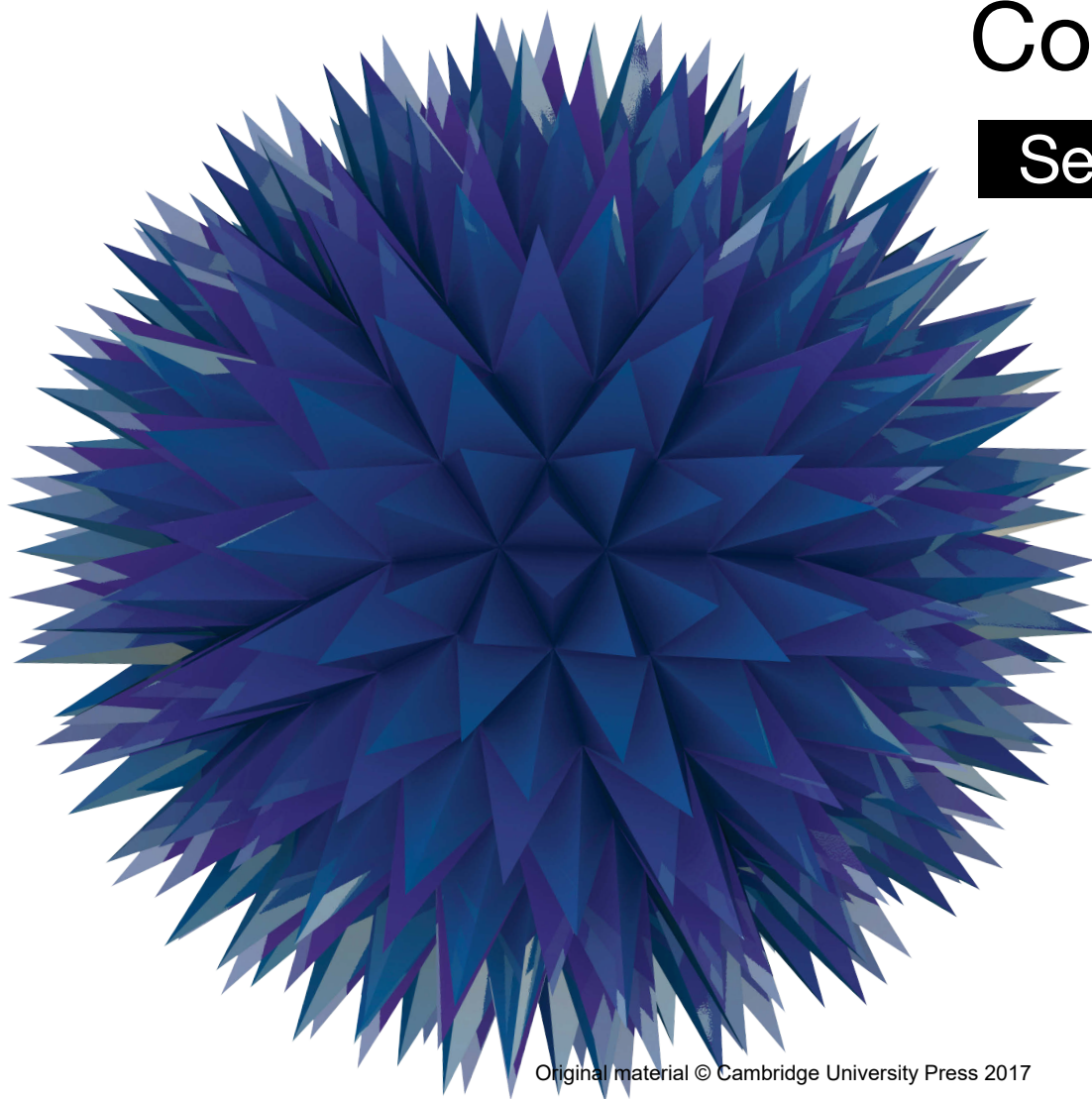

Original material © Cambridge University Press 2017

Completely Cambridge
Cambridge resources
for
Cambridge qualifications

Sue Pemberton

Cambridge IGCSE[®] and O Level

Additional Mathematics

Coursebook

Second edition



CAMBRIDGE
UNIVERSITY PRESS

University Printing House, Cambridge CB2 8BS, United Kingdom
One Liberty Plaza, 20th Floor, New York, NY 10006, USA
477 Williamstown Road, Port Melbourne, VIC 3207, Australia
4843/24, 2nd Floor, Ansari Road, Daryaganj, Delhi – 110002, India
79 Anson Road, 06 -04/06, Singapore 079906

Cambridge University Press is part of the University of Cambridge.
It furthers the University’s mission by disseminating knowledge in the pursuit of education, learning and research at the highest international levels of excellence.

www.cambridge.org

Information on this title: cambridge.org/9781108411660 (Paperback)

© Cambridge University Press 2017

This publication is in copyright. Subject to statutory exception and to the provisions of relevant collective licensing agreements, no reproduction of any part may take place without the written permission of Cambridge University Press.

First published 2016

20 19 18 17 16 15 14 13 12 11 10 9 8 7 6 5 4 3 2 1

Printed in to come

A catalogue record for this publication is available from the British Library

ISBN 9781108411660 Paperback
ISBN 9781108411738 Cambridge Elevate Edition
ISBN 9781108411745 Paperback + Cambridge Elevate Edition

Cambridge University Press has no responsibility for the persistence or accuracy of URLs for external or third-party internet websites referred to in this publication, and does not guarantee that any content on such websites is, or will remain, accurate or appropriate. Information regarding prices, travel timetables, and other factual information given in this work is correct at the time of first printing but Cambridge University Press does not guarantee the accuracy of such information thereafter.

©IGCSE is the registered trademark of Cambridge International Examinations. Past exam paper questions throughout are reproduced by permission of Cambridge International Examinations.

Cambridge International Examinations bears no responsibility for the example answers to questions taken from its past question papers which are contained in this publication.

All exam-style questions and sample answers in this title were written by the authors. In examinations, the way marks are awarded may be different.

.....
NOTICE TO TEACHERS IN THE UK

It is illegal to reproduce any part of this work in material form (including photocopying and electronic storage) except under the following circumstances:

- (i) where you are abiding by a licence granted to your school or institution by the Copyright Licensing Agency;
- (ii) where no such licence exists, or where you wish to exceed the terms of a licence, and you have gained the written permission of Cambridge University Press;
- (iii) where you are allowed to reproduce without permission under the provisions of Chapter 3 of the Copyright, Designs and Patents Act 1988, which covers, for example, the reproduction of short passages within certain types of educational anthology and reproduction for the purposes of setting examination questions.

Contents

Acknowledgements	vi
Introduction	vii
How to use this book	viii
1 Functions	1
1.1 Mappings	2
1.2 Definition of a function	3
1.3 Composite functions	5
1.4 Modulus functions	7
1.5 Graphs of $y = f(x) $ where $f(x)$ is linear	10
1.6 Inverse functions	12
1.7 The graph of a function and its inverse	15
Summary	18
Examination questions	19
2 Simultaneous equations and quadratics	23
2.1 Simultaneous equations (one linear and one non-linear)	25
2.2 Maximum and minimum values of a quadratic function	28
2.3 Graphs of $y = f(x) $ where $f(x)$ is quadratic	34
2.4 Quadratic inequalities	37
2.5 Roots of quadratic equations	39
2.6 Intersection of a line and a curve	42
Summary	44
Examination questions	46
3 Indices and surds	49
3.1 Simplifying expressions involving indices	50
3.2 Solving equations involving indices	51
3.3 Surds	55
3.4 Multiplication, division and simplification of surds	57
3.5 Rationalising the denominator of a fraction	60
3.6 Solving equations involving surds	63
Summary	67
Examination questions	67
4 Factors and polynomials	70
4.1 Adding, subtracting and multiplying polynomials	71
4.2 Division of polynomials	73
4.3 The factor theorem	75
4.4 Cubic expressions and equations	78
4.5 The remainder theorem	82
Summary	86
Examination questions	87
5 Equations, inequalities and graphs	89
5.1 Solving equations of the type $ ax - b = cx - d $	90
5.2 Solving modulus inequalities	94
5.3 Sketching graphs of cubic polynomials and their moduli	98
5.4 Solving cubic inequalities graphically	102
Summary	103
Examination questions	104
6 Logarithmic and exponential functions	107
6.1 Logarithms to base 10	108
6.2 Logarithms to base a	111
6.3 The laws of logarithms	114
6.4 Solving logarithmic equations	116

6.5	Solving exponential equations	118
6.6	Change of base of logarithms	120
6.7	Natural logarithms	122
6.8	Practical applications of exponential equations	124
6.9	The graphs of simple logarithmic and exponential functions	125
6.10	The graphs of $y = k e^{nx} + a$ and $y = k \ln(ax + b)$ where n, k, a and b are integers	126
6.11	The inverse of logarithmic and exponential functions	129
	Summary	130
	Examination questions	131
7	Straight-line graphs	134
7.1	Problems involving length of a line and mid-point	136
7.2	Parallel and perpendicular lines	139
7.3	Equations of straight lines	141
7.4	Areas of rectilinear figures	144
7.5	Converting from a non-linear equation to linear form	147
7.6	Converting from linear form to a non-linear equation	151
7.7	Finding relationships from data	155
	Summary	161
	Examination questions	161
8	Circular measure	166
8.1	Circular measure	167
8.2	Length of an arc	170
8.3	Area of a sector	173
	Summary	176
	Examination questions	177
9	Trigonometry	182
9.1	Angles between 0° and 90°	183
9.2	The general definition of an angle	186
9.3	Trigonometric ratios of general angles	188
9.4	Graphs of trigonometric functions	191
9.5	Graphs of $y = f(x) $, where $f(x)$ is a trigonometric function	201
9.6	Trigonometric equations	204
9.7	Trigonometric identities	210
9.8	Further trigonometric equations	212
9.9	Further trigonometric identities	214
	Summary	216
	Examination questions	217
10	Permutations and combinations	220
10.1	Factorial notation	221
10.2	Arrangements	222
10.3	Permutations	225
10.4	Combinations	229
	Summary	233
	Examination questions	234
11	Series	239
11.1	Pascal's triangle	240
11.2	The binomial theorem	245
11.3	Arithmetic progressions	248
11.4	Geometric progressions	253
11.5	Infinite geometric series	258
11.6	Further arithmetic and geometric series	263
	Summary	266
	Examination questions	267

12 Differentiation 1	270
12.1 The gradient function	271
12.2 The chain rule	276
12.3 The product rule	278
12.4 The quotient rule	281
12.5 Tangents and normals	283
12.6 Small increments and approximations	287
12.7 Rates of change	290
12.8 Second derivatives	294
12.9 Stationary points	296
12.10 Practical maximum and minimum problems	301
Summary	306
Examination questions	307
13 Vectors	311
13.1 Further vector notation	313
13.2 Position vectors	315
13.3 Vector geometry	319
13.4 Constant velocity problems	323
Summary	327
Examination questions	327
14 Differentiation 2	332
14.1 Derivatives of exponential functions	333
14.2 Derivatives of logarithmic functions	337
14.3 Derivatives of trigonometric functions	341
14.4 Further applications of differentiation	346
Summary	352
Examination questions	353
15 Integration	357
15.1 Differentiation reversed	358
15.2 Indefinite integrals	361
15.3 Integration of functions of the form $(ax + b)^n$	363
15.4 Integration of exponential functions	364
15.5 Integration of sine and cosine functions	366
15.6 Integration of functions of the form $\frac{1}{x}$ and $\frac{1}{ax + b}$	368
15.7 Further indefinite integration	371
15.8 Definite integration	374
15.9 Further definite integration	379
15.10 Area under a curve	381
15.11 Area of regions bounded by a line and a curve	387
Summary	392
Examination questions	393
16 Kinematics	397
16.1 Applications of differentiation in kinematics	399
16.2 Applications of integration in kinematics	407
Summary	413
Examination questions	414
Answers	417
Index	449

Chapter 11

Series

This section will show you how to:

- use the binomial theorem for expansion of $(a + b)^n$ for positive integral n
- use the general term $\binom{n}{r} a^{n-r} b^r$ for a binomial expansion
- recognise arithmetic and geometric progressions
- use the formula for the n th term and for the sum of the first n terms to solve problems involving arithmetic and geometric progressions
- use the condition for the convergence of a geometric progression, and the formula for the sum to infinity of a convergent geometric progression.

CLASS DISCUSSION

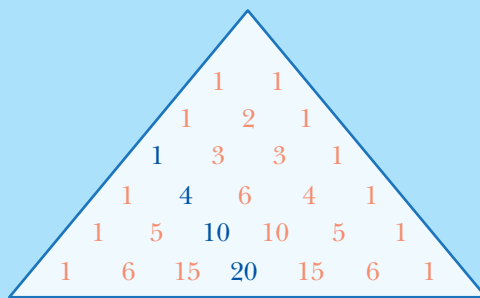

There are many number patterns in Pascal's triangle.

For example, the numbers 1, 4, 10 and 20 have been highlighted.

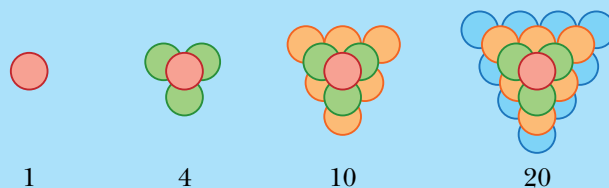

These numbers are called tetrahedral numbers.

Which other number patterns can you find in Pascal's triangle?

What do you notice if you find the total of each row in Pascal's triangle?

WORKED EXAMPLE 1

Use Pascal's triangle to find the expansion of:

a $(2 + 5x)^3$

b $(2x - 3)^4$

Answers

a $(2 + 5x)^3$

The index = 3 so use the 3rd row in Pascal's triangle.

The 3rd row of Pascal's triangle is 1, 3, 3 and 1.

$$\begin{aligned} (2 + 5x)^3 &= 1(2)^3 + 3(2)^2(5x) + 3(2)(5x)^2 + 1(5x)^3 \quad \text{Use the expansion of } (a + b)^3. \\ &= 8 + 60x + 150x^2 + 125x^3 \end{aligned}$$

b $(2x - 3)^4$

The index = 4 so use the 4th row in Pascal's triangle.

The 4th row of Pascal's triangle is 1, 4, 6, 4 and 1.

$$\begin{aligned} (2x - 3)^4 &= 1(2x)^4 + 4(2x)^3(-3) + 6(2x)^2(-3)^2 + 4(2x)(-3)^3 + 1(-3)^4 \quad \text{Use the expansion of } (a + b)^4. \\ &= 16x^4 - 96x^3 + 216x^2 - 216x^3 + 81 \end{aligned}$$

WORKED EXAMPLE 2

- a** Expand $(2 - x)^5$.
b Find the coefficient of x^3 in the expansion of $(1 + 3x)(2 - x)^5$.

Answers

a $(2 - x)^5$

The index = 5 so use the 5th row in Pascal's triangle.

The 5th row of Pascal's triangle is 1, 5, 10, 10, 5 and 1.

$$(2 - x)^5 = 1(2)^5 + 5(2)^4(-x) + 10(2)^3(-x)^2 + 10(2)^2(-x)^3 + 5(2)(-x)^4 + 1(-x)^5$$

$$= 32 - 80x + 80x^2 - 40x^3 + 10x^4 - x^5$$

b $(1 + 3x)(2 - x)^5 = (1 + 3x)(32 - 80x + 80x^2 - 40x^3 + 10x^4 - x^5)$

The term in x^3 comes from the products:

$$(1 + 3x)(32 - 80x + 80x^2 - 40x^3 + 10x^4 - x^5)$$

$$1 \times (-40x^3) = -40x^3 \quad \text{and} \quad 3x \times 80x^2 = 240x^3$$

So the coefficient of x^3 is $-40 + 240 = 200$.

Exercise 11.1

1 Write down the 6th and 7th rows of Pascal's triangle.

2 Use Pascal's triangle to find the expansions of:

a $(1 + x)^3$

b $(1 - x)^4$

c $(p + q)^4$

d $(2 + x)^3$

e $(x + y)^5$

f $(y + 4)^3$

g $(a - b)^3$

h $(2x + y)^4$

i $(x - 2y)^3$

j $(3x - 4)^4$

k $\left(x + \frac{2}{x}\right)^3$

l $\left(x^2 - \frac{1}{2x^3}\right)^3$

3 Find the coefficient of x^3 in the expansions of:

a $(x + 4)^4$

b $(1 + x)^5$

c $(3 - x)^4$

d $(3 + 2x)^3$

e $(x - 2)^5$

f $(2x + 5)^4$

g $(4x - 3)^5$

h $\left(3 - \frac{1}{2}x\right)^4$

4 $(4 + x)^5 + (4 - x)^5 = A + Bx^2 + Cx^4$

Find the value of A , the value of B and the value of C .

5 Expand $(1 + 2x)(1 + 3x)^4$.

6 The coefficient of x in the expansion of $(2 + ax)^3$ is 96.

Find the value of the constant a .

7 a Expand $(3 + x)^4$.

b Use your answer to **part a** to express $(3 + \sqrt{5})^4$ in the form $a + b\sqrt{5}$.

- 8 **a** Expand $(1 + x)^5$.
b Use your answer to **part a** to express
i $(1 + \sqrt{3})^5$ in the form $a + b\sqrt{3}$, **ii** $(1 - \sqrt{3})^5$ in the form $c + d\sqrt{3}$.
c Use your answers to **part b** to simplify $(1 + \sqrt{3})^5 + (1 - \sqrt{3})^5$.
- 9 **a** Expand $(2 - x^2)^4$.
b Find the coefficient of x^6 in the expansion of $(1 + 3x^2)(2 - x^2)^4$.
- 10 Find the coefficient of x in the expansion $\left(x - \frac{3}{x}\right)^5$.
- 11 Find the term independent of x in the expansion of $\left(x^2 + \frac{1}{2x}\right)^3$.

CHALLENGE Q

- 12 **a** Find the first three terms, in ascending powers of y , in the expansion of $(2 + y)^5$.
b By replacing y with $3x - 4x^2$, find the coefficient of x^2 in the expansion of $(2 + 3x - 4x^2)^5$.

CHALLENGE Q

- 13 The coefficient of x^3 in the expansion of $(3 + ax)^5$ is 12 times the coefficient of x^2 in the expansion of $\left(1 + \frac{ax}{2}\right)^4$. Find the value of a .

243

CHALLENGE Q

- 14 **a** Given that $\left(x^2 + \frac{4}{x}\right)^3 - \left(x^2 - \frac{4}{x}\right)^3 = ax^3 + \frac{b}{x^3}$, find the value of a and the value of b .
b Hence, without using a calculator, find the exact value of $\left(2 + \frac{4}{\sqrt{2}}\right)^3 - \left(2 - \frac{4}{\sqrt{2}}\right)^3$.

CHALLENGE Q

- 15 Given that $y = x + \frac{1}{x}$, express:
a $x^3 + \frac{1}{x^3}$ in terms of y
b $x^5 + \frac{1}{x^5}$ in terms of y .

CLASS DISCUSSION

The stepping stone game

The rules are that you can move East \rightarrow or South \downarrow from any stone.

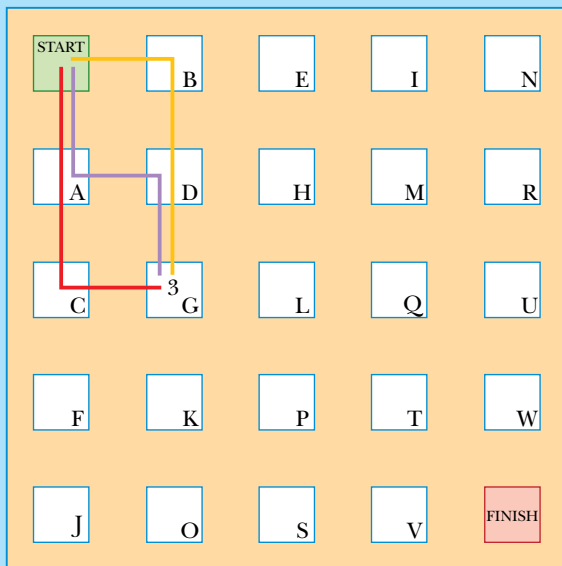

The diagram shows there are 3 routes from the START stone to stone G.

1 Find the number of routes from the START stone to each of the following stones:

- a** i A ii B
b i C ii D iii E
c i F ii G iii H iv I

What do you notice about your answers to **parts a, b** and **c**?

2 There are 6 routes from the START to stone L.

How could you have calculated that there are 6 routes without drawing or visualising them?

3 What do you have to do to find the number of routes to any stone?

4 How many routes are there from the START stone to the FINISH stone?

In the class discussion you should have found that the number of routes from the START stone to stone Q is 10.

To move from START to Q you must move East (E) 3 and South (S) 2, in any order.

Hence the number of routes is the same as the number of different combinations of 3 E's and 2 S's.

The combinations are:

EEESS EESES EESSE ESESE ESEES
 ESSEE SSEEE SESEE SEESE SEEES

So the number of routes is 10.

This is the same as 5C_3 (or 5C_2).

11.2 The binomial theorem

Pascal's triangle can be used to expand $(a + b)^n$ for any positive integer n , but if n is large it can take a long time. Combinations can be used to help expand binomial expressions more quickly.

Using a calculator:

$${}^5C_0 = 1 \quad {}^5C_1 = 5 \quad {}^5C_2 = 10 \quad {}^5C_3 = 10 \quad {}^5C_4 = 5 \quad {}^5C_5 = 1$$

These numbers are the same as the numbers in the 5th row of Pascal's triangle.

So the expansion of $(a + b)^5$ is:

$$(a + b)^5 = {}^5C_0 a^5 + {}^5C_1 a^4 b + {}^5C_2 a^3 b^2 + {}^5C_3 a^2 b^3 + {}^5C_4 a b^4 + {}^5C_5 b^5$$

This can be written more generally as:

$$(a + b)^n = {}^nC_0 a^n + {}^nC_1 a^{n-1} b + {}^nC_2 a^{n-2} b^2 + {}^nC_3 a^{n-3} b^3 + \dots + {}^nC_r a^{n-r} b^r + \dots + {}^nC_n b^n$$

But ${}^nC_0 = 1$ and ${}^nC_n = 1$, so the formula simplifies to:

$$(a + b)^n = a^n + {}^nC_1 a^{n-1} b + {}^nC_2 a^{n-2} b^2 + {}^nC_3 a^{n-3} b^3 + \dots + {}^nC_r a^{n-r} b^r + \dots + b^n$$

or

$$(a + b)^n = a^n + \binom{n}{1} a^{n-1} b + \binom{n}{2} a^{n-2} b^2 + \binom{n}{3} a^{n-3} b^3 + \dots + \binom{n}{r} a^{n-r} b^r + \dots + b^n$$

The formulae above are known as the **binomial theorem**.

WORKED EXAMPLE 3

Use the binomial theorem to expand $(3 + 4x)^5$.

Answers

$$\begin{aligned} (3 + 4x)^5 &= 3^5 + {}^5C_1 3^4(4x) + {}^5C_2 3^3(4x)^2 + {}^5C_3 3^2(4x)^3 + {}^5C_4 3(4x)^4 + (4x)^5 \\ &= 243 + 1620x + 4320x^2 + 5760x^3 + 3840x^4 + 1024x^5 \end{aligned}$$

WORKED EXAMPLE 4

Find the coefficient of x^{20} in the expansion of $(2 - x)^{25}$.

Answers

$$\begin{aligned} (2 - x)^{25} &= 2^{25} + {}^{25}C_1 2^{24} (-x) + {}^{25}C_2 2^{23} (-x)^2 + \dots + {}^{25}C_{20} 2^5 (-x)^{20} + \dots + (-x)^{25} \\ \text{The term containing } x^{20} &\text{ is } {}^{25}C_{20} \times 2^5 \times (-x)^{20}. \\ &= 53\,130 \times 32 \times x^{20} \\ &= 1\,700\,160x^{20} \end{aligned}$$

So the coefficient of x^{20} is 1 700 160.

Using the binomial theorem,

$$(1+x)^7 = 1^7 + {}^7C_1 1^6 x + {}^7C_2 1^5 x^2 + {}^7C_3 1^4 x^3 + {}^7C_4 1^3 x^4 + \dots$$

$$= 1 + {}^7C_1 x + {}^7C_2 x^2 + {}^7C_3 x^3 + {}^7C_4 x^4 + \dots$$

But 7C_1 , 7C_2 , 7C_3 and 7C_4 can also be written as:

$${}^7C_1 = \frac{7!}{1!6!} = 7 \quad {}^7C_2 = \frac{7!}{2!5!} = \frac{7 \times 6}{2!} \quad {}^7C_3 = \frac{7!}{3!4!} = \frac{7 \times 6 \times 5}{3!}$$

$${}^7C_4 = \frac{7!}{4!3!} = \frac{7 \times 6 \times 5 \times 4}{4!}$$

$$\text{So, } (1+x)^7 = 1 + 7x + \frac{7 \times 6}{2!} x^2 + \frac{7 \times 6 \times 5}{3!} x^3 + \frac{7 \times 6 \times 5 \times 4}{4!} x^4 + \dots$$

This leads to an alternative formula for binomial expansions:

$$(1+x)^n = 1 + nx + \frac{n(n-1)}{2!} x^2 + \frac{n(n-1)(n-2)}{3!} x^3 + \frac{n(n-1)(n-2)(n-3)}{4!} x^4 + \dots$$

The following example illustrates how this alternative formula can be applied.

WORKED EXAMPLE 5

Find the first four terms of the binomial expansion to

a $(1+3y)^7$ **b** $(2-y)^6$

Answers

$$\begin{aligned} \mathbf{a} \quad (1+3y)^7 &= 1 + 7(3y) + \frac{7 \times 6}{2!} (3y)^2 + \frac{7 \times 6 \times 5}{3!} (3y)^3 + \dots \\ &= 1 + 21y + 189y^2 + 945y^3 + \dots \end{aligned}$$

Replace x by $3y$ and n by 7 in the formula.

$$\begin{aligned} \mathbf{b} \quad (2-y)^6 &= \left[2 \left(1 - \frac{y}{2} \right) \right]^6 \\ &= 2^6 \left(1 - \frac{y}{2} \right)^6 \\ &= 2^6 \left[1 + 6 \left(-\frac{y}{2} \right) + \frac{6 \times 5}{2!} \left(-\frac{y}{2} \right)^2 + \frac{6 \times 5 \times 4}{3!} \left(-\frac{y}{2} \right)^3 + \dots \right] \\ &= 2^6 \left[1 - 3y + \frac{15}{4} y^2 - \frac{5}{2} y^3 + \dots \right] \\ &= 64 - 192y + 240y^2 - 160y^3 + \dots \end{aligned}$$

The formula is for $(1+x)^n$ so take out a factor of 2 .

Replace x by $\left(-\frac{y}{2}\right)$ and n by 6 in the formula.

Multiply terms in brackets by 2^6 .

Exercise 11.2

1 Write the following rows of Pascal's triangle using combination notation.

a row 3

b row 4

c row 5

2 Use the binomial theorem to find the expansions of:

a $(1+x)^4$

b $(1-x)^5$

c $(1+2x)^4$

d $(3+x)^3$

e $(x+y)^4$

f $(2-x)^5$

g $(a-2b)^4$

h $(2x+3y)^4$

i $\left(\frac{1}{2}x-3\right)^4$

j $\left(1-\frac{x}{10}\right)^5$

k $\left(x-\frac{3}{x}\right)^5$

l $\left(x^2+\frac{1}{2x^2}\right)^6$.

3 Find the term in x^3 for each of the following expansions:

a $(2+x)^5$

b $(5+x)^8$

c $(1+2x)^6$

d $(3+2x)^5$

e $(1-x)^6$

f $(2-x)^9$

g $(10-3x)^7$

h $(4-5x)^{15}$.

4 Use the binomial theorem to find the first three terms in each of these expansions:

a $(1+x)^{10}$

b $(1+2x)^8$

c $(1-3x)^7$

d $(3+2x)^6$

e $(3-x)^9$

f $\left(2+\frac{1}{2}x\right)^8$

g $(5-x^2)^9$

h $(4x-5y)^{10}$.

5 **a** Write down, in ascending powers of x , the first 4 terms in the expansion of $(1+2x)^6$.

b Find the coefficient of x^3 in the expansions of $\left(1-\frac{x}{3}\right)(1+2x)^6$.

6 **a** Write down, in ascending powers of x , the first 4 terms in the expansion of $\left(1+\frac{x}{2}\right)^{13}$.

b Find the coefficient of x^3 in the expansions of $(1+3x)\left(1+\frac{x}{2}\right)^{13}$.

7 **a** Write down, in ascending powers of x , the first 4 terms in the expansion of $(1-3x)^{10}$.

b Find the coefficient of x^3 in the expansions of $(1-4x)(1-3x)^{10}$.

8 **a** Find, in ascending powers of x , the first 3 terms of the expansion of $(1+2x)^7$.

b Hence find the coefficient of x^2 in the expansion of $(1+2x)^7(1-3x+5x^2)$.

9 **a** Find, in ascending powers of x , the first 4 terms of the expansion of $(1+x)^7$.

b Hence find the coefficient of y^3 in the expansion of $(1+y-y^2)^7$.

10 Find the coefficient of x in the binomial expansion of $\left(x-\frac{3}{x}\right)^7$.

11 Find the term independent of x in the binomial expansion of $\left(x+\frac{1}{2x^2}\right)^9$.

CHALLENGE Q

12 When $(1+ax)^n$ is expanded the coefficients of x^2 and x^3 are equal.

Find a in terms of n .

11.3 Arithmetic progressions

At IGCSE level you learnt that a number sequence is an ordered set of numbers that satisfy a rule and that the numbers in the sequence are called the terms of the sequence. A number sequence is also called a **progression**.

The sequence 5, 8, 11, 14, 17, ... is called an **arithmetic progression**. Each term differs from the term before by a constant. This constant is called the **common difference**.

The notation used for arithmetic progressions is:

$$a = \text{first term} \quad d = \text{common difference} \quad l = \text{last term}$$

The first five terms of an arithmetic progression whose first term is a and whose common difference is d are:

$$\begin{array}{ccccc} a & a + d & a + 2d & a + 3d & a + 4d \\ \text{term 1} & \text{term 2} & \text{term 3} & \text{term 4} & \text{term 5} \end{array}$$

This leads to the formula:

$$n\text{th term} = a + (n - 1)d$$

WORKED EXAMPLE 6

Find the number of terms in the arithmetic progression $-17, -14, -11, -8, \dots, 58$.

Answers

$$\begin{array}{ll} n\text{th term} = a + (n - 1)d & \text{use } a = -17, d = 3 \text{ and } n\text{th term} = 58 \\ 58 = -17 + 3(n - 1) & \text{solve} \\ n - 1 = 25 & \\ n = 26 & \end{array}$$

WORKED EXAMPLE 7

The fifth term of an arithmetic progression is 4.4 and the ninth term is 7.6. Find the first term and the common difference.

Answers

$$\begin{array}{ll} 5\text{th term} = 4.4 & \Rightarrow a + 4d = 4.4 \text{ -----(1)} \\ 9\text{th term} = 7.6 & \Rightarrow a + 8d = 7.6 \text{ -----(2)} \\ \text{(2) - (1), gives } 4d = 3.2 & \\ d = 0.8 & \\ \text{Substituting in (1) gives } a + 3.2 = 4.4 & \\ a = 1.2 & \\ \text{First term} = 1.2, \text{ common difference} = 0.8. & \end{array}$$

WORKED EXAMPLE 8

The n th term of an arithmetic progression is $11 - 3n$. Find the first term and the common difference.

Answers

1st term = $11 - 3(1) = 8$ substitute $n = 1$ into n th term = $11 - 3n$

2nd term = $11 - 3(2) = 5$ substitute $n = 2$ into n th term = $11 - 3n$

Common difference = 2nd term - 1st term = -3 .

The sum of an arithmetic progression

When the terms in a sequence are added together the resulting sum is called a **series**.

CLASS DISCUSSION

$$1 + 2 + 3 + 4 + \dots + 97 + 98 + 99 + 100 = ?$$

It is said that at the age of eight, the famous mathematician Carl Gauss was asked to find the sum of the numbers from 1 to 100. His teacher expected this task to keep him occupied for some time but Gauss surprised his teacher by writing down the correct answer after just a couple of seconds. His method involved adding the numbers in pairs: $1 + 100 = 101$, $2 + 99 = 101$, $3 + 98 = 101$, ...

- 1 Can you complete his method to find the answer?
- 2 Use Gauss's method to find the sum of
 - a $2 + 4 + 6 + 8 + \dots + 394 + 396 + 398 + 400$
 - b $3 + 6 + 9 + 12 + \dots + 441 + 444 + 447 + 450$
 - c $17 + 24 + 31 + 15 + \dots + 339 + 346 + 353 + 360$.
- 3 Use Gauss's method to find an expression, in terms of n , for the sum $1 + 2 + 3 + 4 + \dots + (n - 3) + (n - 2) + (n - 1) + n$.

It can be shown that the sum of an arithmetic progression, S_n , can be written as:

$$S_n = \frac{n}{2}(a+l) \quad \text{or} \quad S_n = \frac{n}{2}[2a + (n-1)d]$$

Proof: $S_n = a + (a + d) + (a + 2d) + \dots + (l - 2d) + (l - d) + l$

Reversing: $S_n = l + (l - d) + (l - 2d) + \dots + (a + 2d) + (a + d) + a$

Adding: $2S_n = n(a + l) + (a + l) + (a + l) + \dots + (a + l) + (a + l) + (a + l) +$
 $2S_n = n(a + l)$

$$S_n = \frac{n}{2}(a+l)$$

Using $l = a + (n - 1)d$, gives $S_n = \frac{n}{2}[2a + (n - 1)d]$

It is useful to remember the following rule that applies for all progressions:

$$n\text{th term} = S_n - S_{n-1}$$

WORKED EXAMPLE 9

In an arithmetic progression, the 1st term is 25, the 19th term is -38 and the last term is -87 . Find the sum of all the terms in the progression.

Answers

$$\begin{aligned} n\text{th term} &= a + (n - 1)d && \text{use } n\text{th term} = -38 \text{ when } n = 19 \text{ and } a = 25 \\ -38 &= 25 + 18d && \text{solve} \\ d &= -3.5 \end{aligned}$$

$$\begin{aligned} n\text{th term} &= a + (n - 1)d && \text{use } n\text{th term} = -87 \text{ when } a = 25 \text{ and } d = -3.5 \\ -87 &= 25 - 3.5(n - 1) && \text{solve} \\ n - 1 &= 32 \\ n &= 33 \end{aligned}$$

$$S_n = \frac{n}{2}(a + l) \quad \text{use } a = 25, l = -87 \text{ and } n = 33$$

$$\begin{aligned} S_{33} &= \frac{33}{2}(25 - 87) \\ &= -1023 \end{aligned}$$

WORKED EXAMPLE 10

The 12th term in an arithmetic progression is 8 and the sum of the first 13 terms is 78. Find the first term of the progression and the common difference.

Answers

$$\begin{aligned} n\text{th term} &= a + (n - 1)d && \text{use } n\text{th term} = 8 \text{ when } n = 12 \\ 8 &= a + 11d \text{----- (1)} \end{aligned}$$

$$S_n = \frac{n}{2}[2a + (n - 1)d] \quad \text{use } n = 13 \text{ and } S_{13} = 78$$

$$78 = \frac{13}{2}(2a + 12d) \quad \text{simplify}$$

$$6 = a + 6d \text{----- (2)}$$

$$(1) - (2) \text{ gives } 5d = 2$$

$$d = 0.4$$

Substituting $d = 0.4$ in equation (1) gives $a = 3.6$.

First term = 3.6, common difference = 0.4.

WORKED EXAMPLE 11

The sum of the first n terms, S_n , of a particular arithmetic progression is given by $S_n = 5n^2 - 3n$.

- a** Find the first term and the common difference.
b Find an expression for the n th term.

Answers

$$\begin{aligned} \mathbf{a} \quad S_1 &= 5(1)^2 - 3(1) = 2 & \Rightarrow & \text{first term} = 2 \\ S_2 &= 5(2)^2 - 3(2) = 14 & \Rightarrow & \text{first term} + \text{second term} = 14 \\ & & & \text{second term} = 14 - 2 = 12 \end{aligned}$$

First term = 2, common difference = 10.

b Method 1:

$$\begin{aligned} \text{nth term} &= a + (n-1)d & \text{use } a = 2, d = 10 \\ &= 2 + 10(n-1) \\ &= 10n - 8 \end{aligned}$$

Method 2:

$$\begin{aligned} \text{nth term} &= S_n - S_{n-1} = 5n^2 - 3n - [5(n-1)^2 - 3(n-1)] \\ &= 5n^2 - 3n - (5n^2 - 10n + 5 - 3n + 3) \\ &= 10n - 8 \end{aligned}$$

Exercise 11.3

- The first term in an arithmetic progression is a and the common difference is d .
Write down expressions, in terms of a and d , for the 5th term and the 14th term.
- Find the sum of each of these arithmetic series.

a $2 + 9 + 16 + \dots$ (15 terms)	b $20 + 11 + 2 + \dots$ (20 terms)
c $8.5 + 10 + 11.5 + \dots$ (30 terms)	d $-2x - 5x - 8x - \dots$ (40 terms)
- Find the number of terms and the sum of each of these arithmetic series.

a $23 + 27 + 31 \dots + 159$	b $28 + 11 - 6 - \dots - 210$
-------------------------------------	--------------------------------------
- The first term of an arithmetic progression is 2 and the sum of the first 12 terms is 618.
Find the common difference.
- In an arithmetic progression, the 1st term is -13 , the 20th term is 82 and the last term is 112.

a Find the common difference and the number of terms.
b Find the sum of the terms in this progression.
- The first two terms in an arithmetic progression are 57 and 46. The last term is -207 . Find the sum of all the terms in this progression.

- 7 The first two terms in an arithmetic progression are -2 and 5 . The last term in the progression is the only number in the progression that is greater than 200 . Find the sum of all the terms in the progression.
- 8 The first term of an arithmetic progression is 8 and the last term is 34 . The sum of the first six terms is 58 . Find the number of terms in this progression.
- 9 Find the sum of all the integers between 100 and 400 that are multiples of 6 .
- 10 The first term of an arithmetic progression is 7 and the eleventh term is 32 . The sum of all the terms in the progression is 2790 . Find the number of terms in the progression.
- 11 Rafiu buys a boat for $\$15\,500$. He pays for this boat by making monthly payments that are in arithmetic progression. The first payment that he makes is $\$140$ and the debt is fully repaid after 31 payments. Find the fifth payment.
- 12 The eighth term of an arithmetic progression is -10 and the sum of the first twenty terms is -350 .
- a Find the first term and the common difference.
- b Given that the n th term of this progression is -97 , find the value of n .
- 13 The sum of the first n terms, S_n , of a particular arithmetic progression is given by $S_n = 4n^2 + 2n$. Find the first term and the common difference.
- 14 The sum of the first n terms, S_n , of a particular arithmetic progression is given by $S_n = -3n^2 - 2n$. Find the first term and the common difference.
- 15 The sum of the first n terms, S_n , of a particular arithmetic progression is given by $S_n = \frac{n}{12}(4n + 5)$. Find an expression for the n th term.
- 16 A circle is divided into twelve sectors. The sizes of the angles of the sectors are in arithmetic progression. The angle of the largest sector is 6.5 times the angle of the smallest sector. Find the angle of the smallest sector.
- 17 An arithmetic sequence has first term a and common difference d . The sum of the first 25 terms is 15 times the sum of the first 4 terms.
- a Find d in terms of a .
- b Find the 55 th term in terms of a .
- 18 The eighth term in an arithmetic progression is three times the third term. Show that the sum of the first eight terms is four times the sum of the first four terms.

CHALLENGE Q

- 19 The first term of an arithmetic progression is $\cos^2 x$ and the second term is 1 .
- a Write down an expression, in terms of $\cos x$, for the seventh term of this progression.
- b Show that the sum of the first twenty terms of this progression is $20 + 170 \sin^2 x$.

CHALLENGE Q

- 20** The sum of the digits in the number 56 is 11. ($5 + 6 = 11$)
- Show that the sum of the digits of the integers from 15 to 18 is 30.
 - Find the sum of the digits of the integers from 1 to 100.

11.4 Geometric progressions

The sequence 7, 14, 28, 56, 112, ... is called a **geometric progression**. Each term is double the preceding term. The constant multiple is called the **common ratio**.

The notation used for a geometric progression is:

$$a = \text{first term} \quad r = \text{common ratio}$$

The first five terms of a geometric progression whose first term is a and whose common ratio is r are:

$$\begin{array}{ccccc} a & ar & ar^2 & ar^3 & ar^4 \\ \text{term 1} & \text{term 2} & \text{term 3} & \text{term 4} & \text{term 5} \end{array}$$

This leads to the formula:

$$n\text{th term} = ar^{n-1}$$

WORKED EXAMPLE 12

The 3rd term of a geometric progression is 144 and the common ratio is $\frac{3}{2}$. Find the 7th term and an expression for the n th term.

Answers

$$n\text{th term} = ar^{n-1} \quad \text{use } n\text{th term} = 144 \text{ when } n = 3 \text{ and } r = \frac{3}{2}$$

$$144 = a\left(\frac{3}{2}\right)^2$$

$$a = 64$$

$$7\text{th term} = 64\left(\frac{3}{2}\right)^6 = 729$$

$$n\text{th term} = ar^{n-1} = 64\left(\frac{3}{2}\right)^{n-1}$$

WORKED EXAMPLE 13

The 2nd and 4th terms in a geometric progression are 108 and 48 respectively. Given that all the terms are positive, find the 1st term and the common ratio. Hence, write down an expression for the n th term.

Answers

$$108 = ar \text{-----(1)} \quad 48 = ar^3 \text{-----(2)}$$

$$(2) \div (1) \text{ gives } \frac{ar^3}{ar} = \frac{48}{108}$$

$$r^2 = \frac{4}{9}$$

$$r = \pm \frac{2}{3}$$

all terms are positive $n \Rightarrow > 0$

$$r = \frac{2}{3}$$

Substituting $r = \frac{2}{3}$ into equation (1) gives $a = 162$.

First term = 162, common ratio = $\frac{2}{3}$, n th term = $162\left(\frac{2}{3}\right)^{n-1}$.

WORKED EXAMPLE 14

The n th term of a geometric progression is $30\left(-\frac{1}{2}\right)^n$. Find the first term and the common ratio.

Answers

$$\text{1st term} = 30\left(-\frac{1}{2}\right)^1 = -15$$

$$\text{2nd term} = 30\left(-\frac{1}{2}\right)^2 = 7.5$$

$$\text{Common ratio} = \frac{\text{2nd term}}{\text{1st term}} = \frac{7.5}{-15} = -\frac{1}{2}$$

$$\text{First term} = -15, \text{ common ratio} = -\frac{1}{2}.$$

WORKED EXAMPLE 15

In the geometric sequence 2, 6, 18, 54, ... which is the first term to exceed 1000000?

Answers

$$n\text{th term} = ar^{n-1}$$

use $a = 2$ and $r = 3$

$$23^{n-1} > 1000000$$

divide by 2 and take logs

$$\log_{10} 3^{n-1} > \log_{10} 500000$$

use the power rule for logs

$$(n-1) \log_{10} 3 > \log_{10} 500000$$

divide both sides by $\log_{10} 3$

$$n-1 > \frac{\log_{10} 500000}{\log_{10} 3}$$

$$n-1 > 11.94\dots$$

$$n > 12.94\dots$$

The 13th term is the first to exceed 1000000.

CLASS DISCUSSION

In this class discussion you are not allowed to use a calculator.

- 1** Consider the sum of the first 10 terms, S_{10} , of a geometric progression with $a = 1$ and $r = 5$.

$$S_{10} = 1 + 5 + 5^2 + 5^3 + \dots + 5^7 + 5^8 + 5^9$$

- a** Multiply both sides of the equation above by the common ratio, 5, and complete the following statement.

$$5S_{10} = 5 + 5^2 + 5^3 + \dots + 5^9 + 5^{10} + 5^{11}$$

- b** What happens when you subtract the equation for S_{10} from the equation for $5S_{10}$?

- c** Can you find an alternative way of expressing the sum S_{10} ?

- 2** Use the method from **question 1** to find an alternative way of expressing each of the following:

a $3 + 32 + 32^2 + 32^3 + \dots$ (12 terms)

b $32 + 32\frac{1}{2} + 32\left(\frac{1}{2}\right)^2 + 32\left(\frac{1}{2}\right)^3 + \dots$ (15 terms)

c $27 - 18 + 12 - 8 + \dots$ (20 terms)

It can be shown that the sum of a geometric progression, S_n , can be written as:

$$S_n = \frac{a(1-r^n)}{1-r} \quad \text{or} \quad S_n = \frac{a(r^n-1)}{r-1}$$



Note:
For these formulae, $r \neq 1$

Either formula can be used but it is usually easier to

- use the first formula when $-1 < r < 1$.
- use the second formula when $r > 1$ or when $r < -1$.

Proof:

$$S_n = a + ar + ar^2 + \dots + ar^{n-3} + ar^{n-2} + ar^{n-1} \quad \text{-----(1)}$$

$$r \times (1): \quad rS_n = ar + ar^2 + \dots + ar^{n-3} + ar^{n-2} + ar^{n-1} + ar^n \quad \text{-----(2)}$$

$$(2) - (1): \quad rS_n - S_n = ar^n - a$$

$$(r-1)S_n = a(r^n - 1)$$

$$S_n = \frac{a(r^n - 1)}{r - 1}$$

Multiplying numerator and denominator by -1 gives the alternative formula $S_n = \frac{a(1 - r^n)}{1 - r}$.

WORKED EXAMPLE 16

Find the sum of the first ten terms of the geometric series $2 + 6 + 18 + 54 + \dots$

Answers

$$S_n = \frac{a(r^n - 1)}{r - 1} \quad \text{use } a = 2, r = 3 \text{ and } n = 10$$

$$S_{12} = \frac{2(3^{10} - 1)}{3 - 1}$$

simplify

$$= 59048$$

256

WORKED EXAMPLE 17

The second term of a geometric progression is 9 less than the first term. The sum of the second and third terms is 30. Given that all the terms in the progression are positive, find the first term.

Answers

$$\text{2nd term} = \text{1st term} - 9$$

$$ar = a - 9 \quad \text{rearrange to make } a \text{ the subject}$$

$$a = \frac{9}{1 - r} \quad \text{-----(1)}$$

$$\text{2nd term} + \text{3rd term} = 30$$

$$ar + ar^2 = 30 \quad \text{factorise}$$

$$ar(1 + r) = 30 \quad \text{-----(2)}$$

$$(2) \div (1) \text{ gives } \frac{ar(1+r)}{a} = \frac{30(1-r)}{9} \quad \text{simplify}$$

$$3r^2 + 13r - 10 = 0 \quad \text{factorise and solve}$$

$$(3r - 2)(r + 5) = 0$$

$$r = \frac{2}{3} \text{ or } r = -5 \quad \text{all terms are positive } \Rightarrow r > 0$$

$$r = \frac{2}{3}$$

Substituting $r = \frac{2}{3}$ into (1) gives $a = 27$.

First term is 27.

Exercise 11.4

- 1 Identify whether the following sequences are geometric. If they are geometric, write down the common ratio and the eighth term.

a 1, 2, 4, 6, ...	b -1, 4, -16, 64, ...
c 81, 27, 9, 3, ...	d $\frac{2}{11}, \frac{3}{11}, \frac{5}{11}, \frac{8}{11}, \dots$
e 2, 0.4, 0.08, 0.16, ...	f -5, 5, -5, 5, ...
- 2 The first term in a geometric progression is a and the common ratio is r . Write down expressions, in terms of a and r , for the 9th term and the 20th term.
- 3 The 3rd term of a geometric progression is 108 and the 6th term is -32. Find the common ratio and the first term.
- 4 The first term of a geometric progression is 75 and the third term is 27. Find the two possible values for the fourth term.
- 5 The second term of a geometric progression is 12 and the fourth term is 27. Given that all the terms are positive, find the common ratio and the first term.
- 6 The 6th and 13th terms of a geometric progression are $\frac{5}{2}$ and 320 respectively. Find the common ratio, the first term and the 10th term of this progression.
- 7 The sum of the second and third terms in a geometric progression is 30. The second term is 9 less than the first term. Given that all the terms in the progression are positive, find the first term.
- 8 Three consecutive terms of a geometric progression are x , $x + 6$ and $x + 9$. Find the value of x .
- 9 In the geometric sequence $\frac{1}{4}, \frac{1}{2}, 1, 2, 4, \dots$ which is the first term to exceed 500000?
- 10 In the geometric sequence 256, 128, 64, 32, ... which is the first term that is less than 0.001?
- 11 Find the sum of the first eight terms of each of these geometric series.

a $4 + 8 + 16 + 32 + \dots$	b $729 + 243 + 81 + 27 + \dots$
c $2 - 6 + 18 - 54 + \dots$	d $-500 + 1000 - 200 + 40 - \dots$
- 12 The first four terms of a geometric progression are 1, 3, 9 and 27. Find the smallest number of terms that will give a sum greater than 2000000.
- 13 A ball is thrown vertically upwards from the ground. The ball rises to a height of 10m and then falls and bounces. After each bounce it rises to $\frac{4}{5}$ of the height of the previous bounce.
 - a** Write down an expression, in terms of n , for the height that the ball rises after the n th impact with the ground.

- b** Find the total distance that the ball travels from the first throw to the fifth impact with the ground.
- 14** The third term of a geometric progression is nine times the first term. The sum of the first four terms is k times the first term. Find the possible values of k .
- 15** John competes in a 10 km race. He completes the first kilometre in 4 minutes. He reduces his speed in such a way that each kilometre takes him 1.05 times the time taken for the preceding kilometre. Find the total time, in minutes and seconds, John takes to complete the 10 km race. Give your answer correct to the nearest second.
- 16** A geometric progression has first term a , common ratio r and sum to n terms, S_n .

Show that $\frac{S_{3n} - S_{2n}}{S_n} = r^{2n}$.

CHALLENGE Q

17 $1, 1, 3, \frac{1}{3}, 9, \frac{1}{9}, 27, \frac{1}{27}, 81, \frac{1}{81}, \dots$

Show that the sum of the first $2n$ terms of this sequence is $\frac{1}{2}(3^n - 3^{1-n} + 2)$.

258

CHALLENGE Q

18 $S_n = 6 + 66 + 666 + 6666 + 66666 + \dots$

Find the sum of the first n terms of this sequence.

11.5 Infinite geometric series

An infinite series is a series whose terms continue forever.

The geometric series where $a = 2$ and $r = \frac{1}{2}$ is $2 + 1 + \frac{1}{2} + \frac{1}{4} + \frac{1}{8} + \dots$

For this series it can be shown that

$$S_1 = 2, S_2 = 3, S_3 = 3\frac{1}{2}, S_4 = 3\frac{3}{4}, S_5 = 3\frac{7}{8}, \dots$$

This suggests that the sum to infinity approaches the number 4.

The diagram of the 2 by 2 square is a visual representation of this series. If the pattern of rectangles inside the square is continued the total areas of the inside rectangles approaches the value 4.

This confirms that the sum to infinity of the series $2 + 1 + \frac{1}{2} + \frac{1}{4} + \frac{1}{8} + \dots$ is 4.

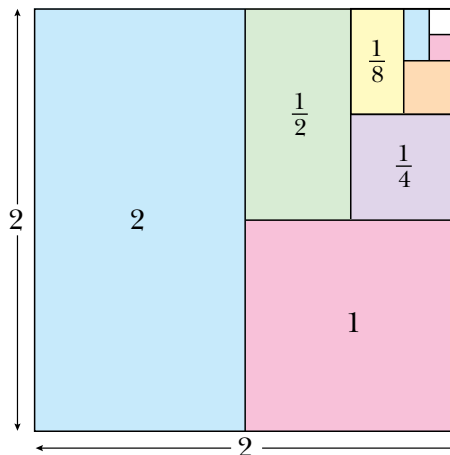

This is an example of a **convergent** series because the sum to infinity converges on a finite number.

CLASS DISCUSSION

- 1 Use a spread sheet to investigate whether the sum of each of these infinite geometric series converge or diverge. If they converge, state their sum to infinity.

$$a = \frac{2}{5}, r = 2$$

$$a = -3, r = -\frac{1}{2}$$

$$a = 5, r = \frac{2}{3}$$

$$a = \frac{1}{2}, r = -5$$

- 2 Find other convergent geometric series of your own. In each case find the sum to infinity.
3 Can you find a condition for r for which a geometric series is convergent?

Consider the geometric series $a + ar + ar^2 + ar^3 + \dots + ar^{n-1}$.

The sum, S_n , is given by the formula $S_n = \frac{a(1 - r^n)}{1 - r}$.

If $-1 < r < 1$, then as n gets larger and larger, r^n gets closer and closer to 0.

We say that as $n \rightarrow \infty$, $r^n \rightarrow 0$.

Hence, as $n \rightarrow \infty$, $\frac{a(1 - r^n)}{1 - r} \rightarrow \frac{a(1 - 0)}{1 - r} = \frac{a}{1 - r}$.

This gives the result

$$S_\infty = \frac{a}{1 - r} \text{ provided that } -1 < r < 1$$



Note:
This is not true
when $r > 1$ or
when $r = -1$

259

WORKED EXAMPLE 18

The first three terms of a geometric progression are 25, 15 and 9.

- a** Write down the common ratio.
b Find the sum to infinity.

a Common ratio $\frac{\text{second term}}{\text{first term}} = \frac{15}{25} = \frac{3}{5}$

b $S_\infty = \frac{a}{1 - r}$ use $a = 25$ and $r = \frac{3}{5}$

$$= \frac{25}{1 - \frac{3}{5}}$$

$$= 62.5$$

WORKED EXAMPLE 19

A geometric progression has a common ratio of $-\frac{4}{5}$ and the sum of the first four terms is 164.

- a** Find the first term of the progression.
b Find the sum to infinity.

$$\mathbf{a} \quad S_4 = \frac{a(1-r^4)}{1-r} \qquad \text{use } S_4 = 164 \text{ and } r = -\frac{4}{5}$$

$$164 = \frac{a\left(1 - \left(-\frac{4}{5}\right)^4\right)}{1 - \left(-\frac{4}{5}\right)} \qquad \text{simplify}$$

$$164 = \frac{41}{125}a \qquad \text{solve}$$

$$a = 500$$

$$\mathbf{b} \quad S_\infty = \frac{a}{1-r} \qquad \text{use } a = 500 \text{ and } r = -\frac{4}{5}$$

$$= \frac{500}{1 - \left(-\frac{4}{5}\right)}$$

$$= 277\frac{7}{9}$$

Exercise 11.5

- 1** Find the sum to infinity of each of the following geometric series.

a $3 + 1 + \frac{1}{3} + \frac{1}{9} + \dots$

b $1 - \frac{1}{2} + \frac{1}{4} - \frac{1}{8} + \frac{1}{16} - \dots$

c $8 + \frac{8}{5} + \frac{8}{25} + \frac{8}{125} + \dots$

d $-162 + 108 - 72 + 48 - \dots$

- 2** The first term of a geometric progression is 10 and the second term is 8. Find the sum to infinity.

- 3** The first term of a geometric progression is 300 and the fourth term is $-2\frac{2}{5}$. Find the common ratio and the sum to infinity.

- 4** The first four terms of a geometric progression are 1, 0.8^2 , 0.8^4 and 0.8^6 . Find the sum to infinity.

- 5 a** Write the recurring decimal $0.\dot{4}\dot{2}$ as the sum of a geometric progression.

b Use your answer to **part a** to show that $0.\dot{4}\dot{2}$ can be written as $\frac{14}{33}$.

- 6** The first term of a geometric progression is -120 and the sum to infinity is -72 . Find the common ratio and the sum of the first three terms.

- 7** The second term of a geometric progression is 6.5 and the sum to infinity is 26. Find the common ratio and the first term.
- 8** The second term of a geometric progression is -96 and the fifth term is $40\frac{1}{2}$.
- Find the common ratio and the first term.
 - Find the sum to infinity.
- 9** The first three terms of a geometric progression are 175 , k and 63 . Given that all the terms in the progression are positive, find:
- the value of k
 - the sum to infinity.
- 10** The second term of a geometric progression is 18 and the fourth term is 1.62. Given that the common ratio is positive, find:
- the common ratio and the first term
 - the sum to infinity.
- 11** The first three terms of a geometric progression are $k + 15$, k and $k - 12$ respectively, find:
- the value of k
 - the sum to infinity.
- 12** The fourth term of a geometric progression is 48 and the sum to infinity is three times the first term. Find the first term.
- 13** A geometric progression has first term a and common ratio r . The sum of the first three terms is 62 and the sum to infinity is 62.5. Find the value of a and the value of r .
- 14** The first term of a geometric progression is 1 and the second term is $2\sin x$ where $-\frac{\pi}{2} < x < \frac{\pi}{2}$. Find the set of values of x for which this progression is convergent.
- 15** A ball is dropped from a height of 12 m. After each bounce it rises to $\frac{3}{4}$ of the height of the previous bounce. Find the total vertical distance that the ball travels.

CHALLENGE Q

16 Starting with an equilateral triangle, a Koch snowflake pattern can be constructed using the following steps:

- Step 1:** Divide each line segment into three equal segments.
Step 2: Draw an equilateral triangle, pointing outwards, which has the middle segment from step 1 as its base.
Step 3: Remove the line segments that were used as the base of the equilateral triangles in step 2.

These three steps are then repeated to produce the next pattern.

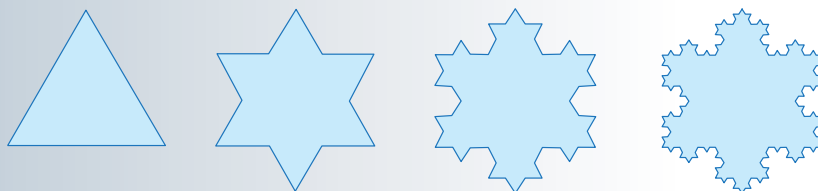

Pattern 1

Pattern 2

Pattern 3

Pattern 4

You are given that the triangle in **pattern 1** has side length x units.

- a** Find, in terms of x , expressions for the perimeter of each of patterns 1, 2, 3 and 4 and explain why this progression for the perimeter of the snowflake diverges to infinity.
b Show that the area of each of patterns 1, 2, 3 and 4 can be written as:

Pattern	Area
1	$\frac{\sqrt{3}x^2}{4}$
2	$\frac{\sqrt{3}x^2}{4} = 3 \frac{\sqrt{3}\left(\frac{x}{3}\right)^2}{4}$
3	$\frac{\sqrt{3}x^2}{4} = 3 \frac{\sqrt{3}\left(\frac{x}{3}\right)^2}{4} + 12 \frac{\sqrt{3}\left(\frac{x}{9}\right)^2}{4}$
4	$\frac{\sqrt{3}x^2}{4} = 3 \frac{\sqrt{3}\left(\frac{x}{3}\right)^2}{4} + 12 \frac{\sqrt{3}\left(\frac{x}{9}\right)^2}{4} + 48 \frac{\sqrt{3}\left(\frac{x}{27}\right)^2}{4}$

Hence show that the progression for the area of the snowflake converges to $\frac{8}{5}$ times the area of the original triangle.

CHALLENGE Q

17 A circle of radius 1 unit is drawn touching the three edges of an equilateral triangle.

Three smaller circles are then drawn at each corner to touch the original circle and two edges of the triangle.

This process is then repeated an infinite number of times.

- Find the sum of the circumferences of all the circles.
- Find the sum of the areas of all the circles.

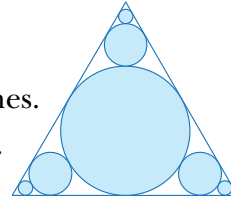

11.6 Further arithmetic and geometric series

Some problems may involve more than one progression.

CLASS DISCUSSION

a, b, c, \dots

- Given that a, b and c are in arithmetic progression, find an equation connecting a, b and c .
- Given that a, b and c are in geometric progression, find an equation connecting a, b and c .

WORKED EXAMPLE 20

The first, second and third terms of an arithmetic series are x, y and x^2 . The first, second and third terms of a geometric series are x, x^2 and y . Given that $x < 0$, find:

- the value of x and the value of y
- the sum to infinity of the geometric series
- the sum of the first 20 terms of the arithmetic series.

a Arithmetic series is: $x + y + x^2 + \dots$ use common differences

$$y - x = x^2 - y$$

$$2y = x^2 + x \quad \text{-----(1)}$$

Geometric series is: $x + x^2 + y + \dots$ use common ratios

$$\frac{y}{x^2} = \frac{x^2}{x}$$

$$y = x^3 \quad \text{-----(2)}$$

(1) and (2) give $2x^3 = x^2 + x$ divide by x (since $x \neq 0$) and rearrange
factorise and solve

$$2x^2 - x - 1 = 0$$

$$(2x + 1)(x - 1) = 0$$

$$x = -\frac{1}{2} \text{ or } x = 1$$

$x \neq 1$ since $x < 0$

$$\text{Hence, } x = -\frac{1}{2} \text{ and } y = -\frac{1}{8}.$$

$$\mathbf{b} \quad S_{\infty} = \frac{a}{1-r}$$

$$\text{use } a = -\frac{1}{2} \text{ and } r = -\frac{1}{2}$$

$$S_{\infty} = \frac{-\frac{1}{2}}{1 - \left(-\frac{1}{2}\right)} = -\frac{1}{3}$$

$$\mathbf{c} \quad S_n = \frac{n}{2}[2a + (n-1)d]$$

$$\text{use } n = 20, a = -\frac{1}{2}, d = y - x = \frac{3}{8}$$

$$S_{20} = \frac{20}{2} \left[-1 + 19 \left(\frac{3}{8} \right) \right] \\ = 61.25$$

Exercise 11.6

- The first term of a progression is 8 and the second term is 12. Find the sum of the first six terms given that the progression is:
 - arithmetic
 - geometric.
- The first term of a progression is 25 and the second term is 20.
 - Given that the progression is geometric, find the sum to infinity.
 - Given that the progression is arithmetic, find the number of terms in the progression if the sum of all the terms is -1550 .
- The 1st, 2nd and 3rd terms of a geometric progression are the 1st, 5th and 11th terms respectively of an arithmetic progression. Given that the first term in each progression is 48 and the common ratio of the geometric progression is r , where $r \neq 1$, find:
 - the value of r ,
 - the 6th term of each progression.
- A geometric progression has six terms. The first term is 486 and the common ratio is $\frac{2}{3}$. An arithmetic progression has 35 terms and common difference $\frac{3}{2}$. The sum of all the terms in the geometric progression is equal to the sum of all the terms in the arithmetic progression. Find the first term and the last term of the arithmetic progression.
- The 1st, 2nd and 3rd terms of a geometric progression are the 1st, 5th and 8th terms respectively of an arithmetic progression. Given that the first term in each progression is 200 and the common ratio of the geometric progression is r , where $r \neq 1$ find:
 - the value of r ,
 - the 4th term of each progression,
 - the sum to infinity of the geometric progression.
- The first term of an arithmetic progression is 12 and the sum of the first 16 terms is 282.

- a** Find the common difference of this progression.
The 1st, 5th and n th term of this arithmetic progression are the 1st, 2nd and 3rd term respectively of a geometric progression.
- b** Find the common ratio of the geometric progression and the value of n .
- 7** The first two terms of a geometric progression are 80 and 64 respectively. The first three terms of this geometric progression are also the 1st, 11th and n th terms respectively of an arithmetic progression. Find the value of n .
- 8** The first two terms of a progression are $5x$ and x^2 respectively.
- a** For the case where the progression is arithmetic with a common difference of 24, find the two possible values of x and the corresponding values of the third term.
- b** For the case where the progression is geometric with a third term of $-\frac{8}{5}$, find the common ratio and the sum to infinity.

Summary

Binomial expansions

If n is a positive integer then $(a + b)^n$ can be expanded using the formula

$$(a + b)^n = a^n + {}^nC_1 a^{n-1} b + {}^nC_2 a^{n-2} b^2 + {}^nC_3 a^{n-3} b^3 + \dots + {}^nC_r a^{n-r} b^r + \dots + b^n$$

or

$$(a + b)^n = a^n + \binom{n}{1} a^{n-1} b + \binom{n}{2} a^{n-2} b^2 + \binom{n}{3} a^{n-3} b^3 + \dots + \binom{n}{r} a^{n-r} b^r + \dots + b^n$$

and where ${}^nC_r = \binom{n}{r} = \frac{n!}{(n-r)!r!}$.

In particular,

$$(1 + x)^n = 1 + nx + \frac{n(n-1)}{2!} x^2 + \frac{n(n-1)(n-2)}{3!} x^3 + \frac{n(n-1)(n-2)(n-3)}{4!} x^4 + \dots + x^n.$$

Arithmetic series

For an arithmetic progression with first term a , common difference d and n terms:

- the k th term = $a + (k - 1)d$
- the last term = $l = a + (n - 1)d$
- the sum of the terms = $S_n = \frac{n}{2}(a + l) = \frac{n}{2}[2a + (n - 1)d]$.

Geometric series

For a geometric progression with first term a , common ratio r and n terms:

- the k th term = ar^{k-1}
- the last term = ar^{n-1}
- the sum of the terms = $S_n = \frac{a(1-r^n)}{1-r} = \frac{a(r^n-1)}{r-1}$.

The condition for a geometric series to converge is $-1 < r < 1$.

When a geometric series converges, $S_\infty = \frac{a}{1-r}$.

Examination questions**Worked past paper example**

- a** Find the first 4 terms in the expansion of $(2 + x^2)^6$ in ascending powers of x . [3]
- b** Find the term independent of x in the expansion of $(2 + x^2)^6 \left(1 - \frac{3}{x^2}\right)^2$. [3]

Cambridge IGCSE Additional Mathematics 0606 Paper 11 Q3i,ii Jun 2015

Answer

- a** Expanding $(2 + x^2)^6$ using the binomial theorem gives
- $$2^6 + {}^6C_1 2^5 x^2 + {}^6C_2 2^4 (x^2)^2 + {}^6C_3 2^3 (x^2)^3 = 64 + 192x^2 + 240x^4 + 160x^6 \dots$$
- b** $(2 + x^2)^6 \left(1 - \frac{2}{x^2}\right)^2 = (64 + 192x^2 + 240x^4 + 160x^6 \dots) \left(1 - \frac{6}{x^2} + \frac{9}{x^4}\right)$
- Term independent of $x = (64 \times 1) + \left(192x^2 \times -\frac{6}{x^2}\right) + \left(240x^4 \times \frac{9}{x^4}\right)$
- $$= 64 - 1152 + 2160$$
- $$= 1072$$

Exercise 11.7**Exam Exercise**

- 1 a** Find the first four terms in the expansion of $(2 + x)^6$ in ascending powers of x . [3]
- b** Hence find the coefficient of x^3 in the expansion of $(1 + 3x)(1 - x)(2 + x)^6$. [4]

Cambridge IGCSE Additional Mathematics 0606 Paper 21 Q7i,ii Jun 2013

- 2 a** Find the first 3 terms, in descending powers of x , in the expansion of $\left(x + \frac{2}{x^2}\right)^6$. [3]
- b** Hence find the term independent of x in the expansion of $\left(2 - \frac{4}{x^3}\right)\left(x + \frac{2}{x^2}\right)^6$. [2]

Cambridge IGCSE Additional Mathematics 0606 Paper 11 Q6i,ii Nov 2012

- 3** The coefficient of x^2 in the expansion of $\left(1 + \frac{x}{5}\right)^n$, where n is a positive integer is $\frac{3}{5}$.
a Find the value of n . [4]

- b** Using this value of n , find the term independent of x in the expansion of

$$\left(1 + \frac{x}{5}\right)^n \left(2 - \frac{3}{x}\right)^2$$
 [4]

Cambridge IGCSE Additional Mathematics 0606 Paper 11 Q7i,ii Nov 2011

- 4 a** Find the coefficient of x^3 in the expansion of $\left(1 - \frac{x}{2}\right)^{12}$. [2]

- b** Find the coefficient of x^3 in the expansion of $(1 + 4x)\left(1 - \frac{x}{2}\right)^{12}$. [3]

Cambridge IGCSE Additional Mathematics 0606 Paper 21 Q2i,ii Jun 2011

- 5 a** Find, in ascending powers of x , the first 3 terms in the expansion of $(2 - 5x)^6$, giving your answer in the form $a + bx + cx^2$, where a , b and c are integers. [3]

- b** Find the coefficient of x in the expansion of $(2 - 5x)^6 \left(1 + \frac{x}{2}\right)^{10}$. [3]

Cambridge IGCSE Additional Mathematics 0606 Paper 11 Q6i,ii Nov 2010

- 6 i** Write down, in ascending powers of x , the first 3 terms in the expansion of $(3 + 2x)^6$. Give each term in its simplest form. [3]

- ii** Hence find the coefficient of x^2 in the expansion of $(2 - x)(3 + 2x)^6$. [2]

Cambridge IGCSE Additional Mathematics 0606 Paper 12 Q4 Mar 2015

- 7 i** Find the first 4 terms in the expansion of $(2 + x^2)^6$ in ascending powers of x . [3]

- ii** Find the term independent of x in the expansion of $(2 + x^2)^6 \left(1 - \frac{3}{x^2}\right)^2$. [3]

Cambridge IGCSE Additional Mathematics 0606 Paper 11 Q3 Jun 2015

- 8 a i** Use the Binomial Theorem to expand $(a + b)^4$, giving each term in its simplest form. [2]

- ii** Hence find the term independent of x in the expansion of $\left(2x + \frac{1}{5x}\right)^4$. [2]

- b** The coefficient of x^3 in the expansion of $\left(1 + \frac{x}{2}\right)^n$ equals $\frac{5n}{12}$. Find the value of the positive integer n . [3]

Cambridge IGCSE Additional Mathematics 0606 Paper 21 Q8 Jun 2016

- 9** The first term of a geometric progression is 35 and the second term is -14 .
- a** Find the fourth term. [3]
- b** Find the sum to infinity. [2]

Examination style question

- 10** The first three terms of a geometric progression are $2k + 6$, $k + 12$ and k respectively. All the terms in the progression are positive.
- a** Find value of k . [3]
- b** Find the sum to infinity. [2]

Examination style question

- 11** An arithmetic progression has first term a and common difference d . Give that the sum of the first 100 terms is 25 times the sum of the first 20 terms.
- a** Find d in terms of a . [3]
- b** Write down an expression, in terms of a , for the 50th. [2]

Examination style question

- 12** The 15th term of an arithmetic progression is 3 and the sum of the first 8 terms is 194.
- a** Find the first term of the progression and the common difference. [4]
- b** Given that the n th term of the progression is -22 , find the value of n . [2]

Examination style question

- 13** The second term of a geometric progression is -576 and the fifth term is 243. Find
- a** the common ratio [3]
- b** the first term [1]
- c** the sum to infinity. [2]

Examination style question

- 14 a** The sixth term of an arithmetic progression is 35 and the sum of the first ten terms is 335. Find the eighth term. [4]
- b** A geometric progression has first term 8 and common ratio r . A second geometric progression has first term 10 and common ratio $\frac{1}{4}r$. The two progressions have the same sum to infinity, S . Find the values of r and the value of S . [3]

Examination style question

- 15 a** The 10th term of an arithmetic progression is 4 and the sum of the first 7 terms is -28 . Find the first term and the common difference. [4]
- b** The first term of a geometric progression is 40 and the fourth term is 5. Find the sum to infinity of the progression. [3]

Examination style question

- 16 a** A geometric progression has first term a , common ratio r and sum to infinity S .
A second geometric progression has first term $3a$, common ratio $2r$ and sum to infinity $4S$. Find the value of r . [3]
- b** An arithmetic progression has first term -24 . The n th term is -13.8 and the $(2n)$ th term is -3 . Find the value of n . [4]

Examination style question